

SOME CONSIDERATIONS ON THE CRYOGENIC CALIBRATION TECHNIQUE FOR MICROWAVE AND MILLIMETER WAVE GROUND-BASED RADIOMETRY

Marcelo A. S. Miacci, marcelo.miacci@gmail.com¹
Carlos F. Angelis, carlos.angelis@cemaden.gov.br¹
Alan J. P. Calheiros, alan.calheiros@cptec.inpe.br²
Luiz A. T. Machado, luiz.machado@cptec.inpe.br²

¹National Center for Monitoring and Warnings of Natural Disasters – CEMADEN, Cachoeira Paulista, Brazil.

²National Institute for Space Research – INPE, Cachoeira Paulista, Brazil.

Abstract—This manuscript describes the cryogenic calibration technique applied to the MP3000A radiometer, which employs a liquid nitrogen (LN₂) cooled target as a temperature primary calibration standard (black body). This instrument has recently been deployed in different parts of Brazil as part of the CHUVA Project field campaigns. Taking into account that a reliable calibration is critical for data retrieval and analysis, a system calibration was performed at 22 - 30 GHz (K band) and 51 - 59 GHz (V band) frequency ranges emphasizing the systematic evaluation of the technique. In order to obtain good results for a number of atmospheric parameters, the brightness temperature observation errors raised by the radiometer should be below 0.5 K. The results show that the errors and deviations in the brightness temperatures measurements associated to the LN₂ calibration are considered satisfactory. However, further studies must be carried out in order to better understand all the effects involved in the retrieval of atmospheric parameters and also to outline system precision enhancements.

Keywords—radiometry; microwave propagation; atmospheric profiling; cryogenic calibration.

1. INTRODUCTION

The main goal in performing a radiometer calibration is to define a direct relationship between the input radiative power emitted from a source detected by the antenna, and the receiver output voltage. Considering that the detector output voltage is proportional to the antenna noise temperature, and this relationship results in a square law, it is assumed that the calibration method described in this paper can be applied to the equipment used in the CHUVA Project.

It can be considered that the full knowledge of all radiometer's specifications, taking into account all the losses, reflections and temperatures, should be sufficient to make the calibration unnecessary. However, the modeling of such parameters for all possible operating conditions is a complex task and would make the instrument expensive and unpractical.

In this context, the radiometer absolute calibration becomes an important point to assure a reliable operation and to better assess errors and deviations found in the brightness temperature measurements (therefore in atmospheric profile's retrievals).

In order to obtain relevant quantitative data from radiometric calibration, mainly for the CHUVA project campaigns (CHUVA, 2009), the errors associated with measurements must be below 0.5 K (Skou, 1989).

The radiometer receiver used in this work has two internal reference sources that automatically provide temperature standards during observations: noise diodes that perform receiver gain measurements, and an internal target operating as a blackbody at room temperature.

However, the losses in the waveguides, the reflection coefficients of other components and the lack of knowledge about the complete radiometric parameters, usually require that an external calibration method, such as a cryogenic calibration, must also be employed. It is recommended especially for the noise diodes calibration, once they are regarded as secondary standards (Westwater et al, 2004).

The calibration method analyzed in this study requires the introduction of a precisely known temperature variation in the input port of the radiometer; this variation is generated by a sequential introduction of two primary sources with a known brightness temperatures values (internal room target and cryogenic target).

2. THE MP3000A RADIOMETER

The MP3000A radiometer measures atmospheric brightness temperature, from which high-resolution vertical temperature and humidity profiles can be derived, as well as low resolution liquid water profiles from the surface to 10 km height.

This atmospheric sounding is very useful for weather forecasting and *nowcasting* (Radiometrics, 2008; Madhulatha et al, 2013). The profile retrievals derived from the radiometer measurements are assessed by an artificial neural network whose accuracy decreases as a function of the height, different from radiosondes. However, the temporal sampling of the radiometer measurements is much higher compared to radiosondes (Knupp et al, 2009). Other techniques recently studied focusing on the improvement of promising results based on retrievals are reported in (Cimini et al, 2011; Sánchez et al, 2013; Marzano et al, 2010).

The instrument incorporates two microwave subsystems that share the same antenna and pointing system. The temperature profiling subsystem uses sky brightness temperatures observations at selected frequencies ranging from 51 to 59 GHz (oxygen absorption complex). The water vapor profiling subsystem uses sky brightness temperatures observations at frequencies between 22 and 30 GHz (water vapor absorption line) (Solheim et al, 1998; Ware et al, 2003).

Surface meteorological sensors are included in the system in order to measure air temperature, relative humidity, barometric pressure and rain occurrence from a rain sensor. An infrared thermometer pointing to the zenith is also assembled internally and its main function is to improve the accuracy of water vapor and liquid water density profiles.

The MP3000A has a signal generated by noise sources (diodes), during its normal operation. When the diodes are enabled, a calibrated brightness temperature level is added to the scene in each observation. This procedure is performed in order to measuring the gain of the system.

The instrument also uses an internal reference target, set at room temperature (used as a blackbody), with dual function: a) to provide a known primary standard for each measurement, and, b) to work together with an external cryogenic target which provides absolute calibration standards for the diodes.

3. CALIBRATION STANDARDS

From the radiation theory principles, a microwave load with a low reflection coefficient presents a noise temperature equals to its physical temperature, and could be assumed as a black body (Ulaby et al, 1986). In this way, a simple solution for a calibration standard is a microwave load connected to the radiometer input cooled by a device with a precisely known temperature.

The microwave load can be cooled using cryogenic techniques by its submersion inside a low boiling point medium, such as liquid helium, that exhibits a complex measurement set-up (Trembath et al, 1968), or liquid nitrogen, more suitable for practical applications (Hardy, 1973).

A second choice could be a cooled target pointed to an antenna connected to the radiometer. A microwave absorber (target) will then emit a brightness temperature (T_B) equal to its physical temperature (T_{MA}), so the antenna will detect this temperature (Fig. (1)).

A practical model of this concept would be a radiometer connected to an antenna through a low loss transmission line (such as a waveguide) with the antenna pointing to the microwave absorber immersed in liquid nitrogen. The absorber and liquid nitrogen must be inside a shielded box, so the antenna will receive the energy emitted only from the absorber cooled at 77 K.

This is possible since the liquid nitrogen reflection coefficient and the refractive index are very low (Rose et al, 2005), ensuring that even the target edges should be properly cooled. A more in depth paper about target calibration errors can be found in (Randa et al, 2005).

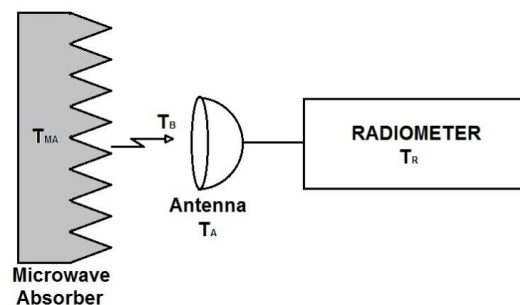

Figure 1. Free space standard target for radiometer calibration.

In the MP3000A case, a slightly different set-up is employed with a calibration load mounted on the top of the instrument (Fig. (2)). Thus, other components start to contribute to the effective blackbody temperature of the cryogenic target. This topic will be discussed in section 4.

There are some alternative methods, like a side-mounted cryogenic calibration that is available commercially and the details of this technique are described in (Löhnert et al, 2012).

4. CONTRIBUTIONS TO THE CALIBRATION CRYOGENIC TARGET

The physical temperature of the cryogenic target is determined by the liquid nitrogen local temperature; nevertheless other factors must be taken into account when calibrating a radiometer. An important parameter regarding the calibration target is its emissivity ϵ (or its reflection coefficient $1 - \epsilon$).

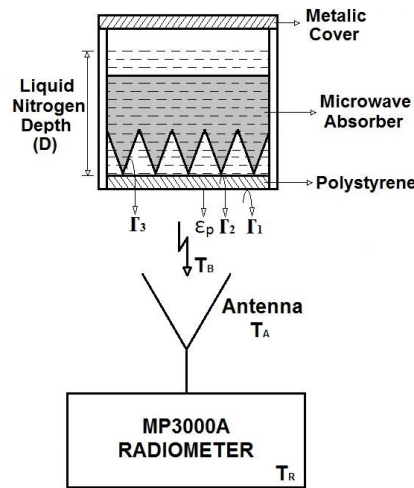

Figure 2. Some contributions to cryogenic target temperature.

If a target is assumed cooled by liquid nitrogen at $T_C = 77K$ and the temperature emitted by the radiometer toward the target is $T_H = 300K$, the radiometer under test will measure the following brightness temperature (T_B):

$$T_B = T_C \cdot \varepsilon + T_H \cdot (1 - \varepsilon) \tag{1}$$

The measurement error (Δ) can be expressed as:

$$\Delta = (T_H - T_C) \cdot (1 - \varepsilon) \tag{2}$$

For example, a target with a return loss (RL) of 20 dB presents a power reflection coefficient ($1/10^{(RL/10)} = 0.01$), which results in an emissivity of 0.99 and an error of 2.23 K (which normally would be unacceptable), however, for a return loss of 40 dB (used in this paper) the error is about 0.02 K.

Another issue to be considered is the boiling point of liquid nitrogen which is a function of ambient barometric pressure (Radiometrics, 2008):

$$T_{LN} = 68.23 + 0.009037 \cdot P \tag{3}$$

where:

T_{LN} : Boiling point of liquid nitrogen (K);

P : Ambient barometric pressure (mb).

A further contribution relates to the hydrostatic load that must be added at atmospheric pressure on the surface of liquid nitrogen and this increase in hydrostatic pressure is approximately 1.2 mb/cm. At a liquid nitrogen depth of 13 cm, the temperature increases by about 0.14 K.

According to Figure 2, the following effects also must be accounted (Hewison et al, 2003):

- Insertion loss of the polystyrene insulation (ε_p): contributes to temperature by emitting to the same extent as the absorption. This procedure causes a frequency dependence given by the dielectric loss coefficient $1.16 \cdot 10^{-5}$ K/K.cm.GHz;

- Reflection from the interface air / polystyrene (Γ_1);
- Reflection from the interface polystyrene / LN2 (Γ_2);
- Reflection from the interface absorber / LN2 (Γ_3).

The sum of the aforementioned reflections results in a power reflection coefficient 0.0078 (Radiometrics, 2008).

Assuming a room temperature of 300 K and a target temperature of 77 K, one can obtain an increase of about 2.5 K apart from the nominal value of liquid nitrogen. These contributions must be considered in the calibration.

5. MEASUREMENTS

The equipment and accessories used to perform the measurements include the following items:

- Radiometer model MP3000A manufactured by Radiometrics Corporation (Fig. (3a));
- Cryogenic target supplied by the manufacturer (Fig. (3b));
- Computer and software for radiometer control and data acquisition (supplied by the manufacturer).

In order to perform the calibration, a suitable site was selected for installation of the radiometer at the Meteorological Instrumentation Laboratory (LIM/INPE) / Cachoeira Paulista - Brazil (22° S 45° W). To minimize the condensation under the target, it was necessary to perform the calibration in dry weather conditions (recommended relative humidity lower than 70%).



Figure 3. (a) MP3000A microwave radiometer profiler. (b) Cryogenic target for radiometer calibration.

In order to assure the complete stabilization of the instrument, the measurements were performed one hour after turn-on of the radiometer. After this procedure, the cryogenic target was installed over the radome at the top of the cabinet (Fig. (4)), and the calibration procedure was launched and executed for two hours. The sampling time of brightness temperatures is approximately 1.5 min.

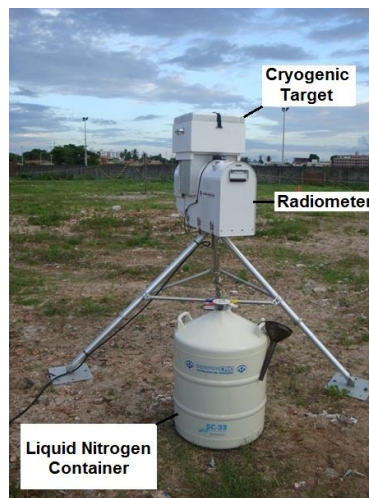

Figure 4. Cryogenic target assembled to perform the calibration.

6. RESULTS

The calibration was verified by running a procedure that switches between observations of the internal ambient target (antenna elevation angle of 270 degrees) and the external cryogenic target (antenna elevation angle of 90 degrees).

The instrument control software automatically performs this procedure and store the brightness temperatures measurements for all microwave channels. If the calibration has been carefully performed, then the brightness temperatures for all channels must be close to the nominal temperature values of the reference targets.

For the internal ambient target it is assumed a temperature given by precision temperature sensors located internally in the radiometer, and the cryogenic target effective temperature is calculated taking into account the contributions described in section IV (typically between 77 and 80 K, depending on the barometric pressure). In this study, it was estimated the nominal temperatures for the cryogenic target ranging from 79.1 (for K band channels) up to 79.6 K (for V band channels).

In order to better illustrate the influence of the cryogenic target effective temperature at the operating frequency, Figure 5 shows some temperature measurements of the target at 22.234 GHz and 57.964 GHz, where one can clearly see the difference between the average temperatures of the channels and confirms the scaling of the target's brightness temperatures to the frequency, as discussed in this section.

In order to verify the measured values, the calculated values for the target effective temperature are plotted in Fig. (5). Figure (6) shows the average errors and standard deviations computed for LN2 and ambient target measurements of all frequency channels.

An observed feature in Fig. (6) is the highest standard deviation in 53.336 GHz channel for both, the ambient target and the cryogenic target; this effect could be attributed to a high phase noise at the receiver local oscillator, and/or some external interference that probably could cause this result.

Table (1) summarizes the error and standard deviation obtained for radiometer calibration for a subset of the channels. The proposed calibration can be regarded as effective method for carrying out observations with errors less than 0.5 K in the most instrument channels.

Among other possible effects of this technique also suggested by other authors (Pospichal et al, 2012), is the fact that the oscillatory pattern on the calibration curve of the liquid nitrogen is due to the phase of the standing waves

detected by the receiver, which can be modified according to the evaporation rate of the nitrogen. In this paper it was not possible to verify this tendency due to differences in the applied methodology.

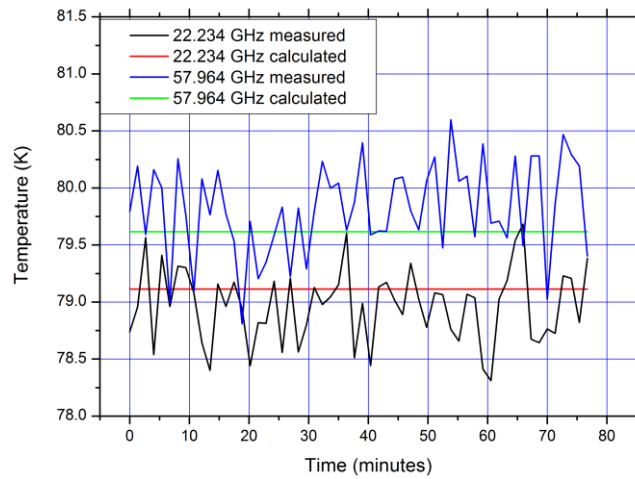

Figure 5. Comparison of measured and calculated temperatures for K and V bands.

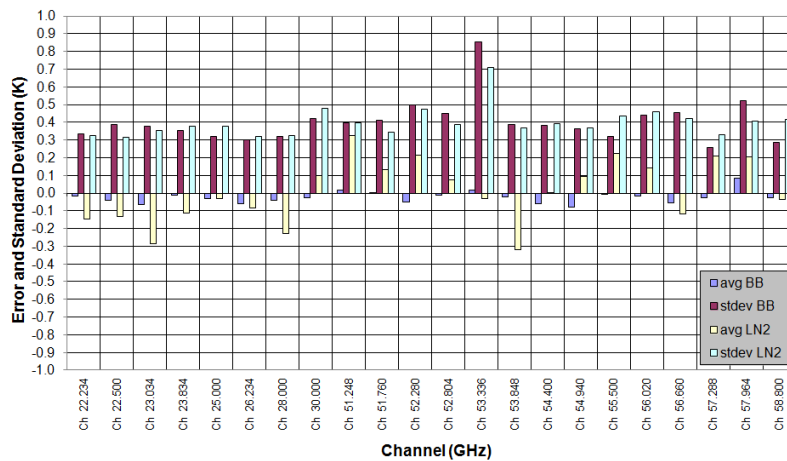

Figure 6. Average errors and standard deviation for calibration using liquid nitrogen (LN2) and internal ambient target (BB).

Table 1: Errors and deviations in the radiometer calibration for a subset of the channels.

Channel (GHz)	Ambient target		Cryogenic target	
	Error (K)	Standard Deviation	Error (K)	Standard Deviation
22.234	-0.015	0.335	-0.147	0.325
23.034	-0.065	0.378	-0.287	0.352
25.000	-0.031	0.321	-0.033	0.378
26.234	-0.062	0.300	-0.082	0.318
30.000	-0.029	0.423	0.101	0.477
51.248	0.017	0.398	0.327	0.398
53.336	0.018	0.852	-0.033	0.711
55.500	-0.009	0.318	0.223	0.434
56.660	-0.057	0.455	-0.117	0.421
57.964	0.083	0.522	0.202	0.406

It is expected that integrated water vapor can be obtained with an accuracy better than 0.5 kgm^{-2} and cloud liquid water path with an accuracy of 20 gm^{-2} and the error for the retrieved quantities should be less than 1 K for temperature profiles in the boundary layer and 2 K above, once reached the brightness temperature accuracy of the radiometer better than 0.5 K which can only be assured by regular sensor calibration (Pospichal et al, 2012).

According to (McGrath et al, 2001) scattering from the polystyrene interface in frequencies above V-band could result in a significant contribution.

7. CONCLUSION

A systematic radiometer calibration was performed using an external cryogenic target to quantify the errors involved in this technique and some influences of the primary temperature standards. According to the results, it was found that the measured values met the manufacturer specifications and was employed in the CHUVA project and other field campaigns.

In order to optimize the accuracy of brightness temperatures measurements, it is recommended that this procedure should be done every six to twelve months, depending on operational conditions, and when the instrument is moved to another place.

More detailed studies should be done to precisely determine the effects of errors associated to the cryogenic calibration target and their implications for brightness temperature measurements and retrieval of atmospheric profiles.

Moreover, additional techniques will be further studied such as the tipping curve (Han et al, 2000), which provides better results in the K-band channels and the effects of noise injection in the microwave channels by the calibrated sources as a secondary standard temperature.

8. ACKNOWLEDGMENT

The authors wish to thank LIM / INPE for assistance in using the available facilities and the CHUVA project team for the technical support. This work was supported by the Sao Paulo Research Foundation, FAPESP Grant 09/15235-8 and 11/03093-4 and by the National Council for Science and Technology Development, CNPq Grant 382630/2013-0.

9. REFERENCES

- CHUVA Project, “Cloud processes of the main precipitation systems in Brazil: A contribution to cloud resolving modeling and to the GPM (Global Precipitation Measurement)”; available: <http://chuvaproject.cptec.inpe.br/>.
- Cimini, D., Campos, E., Ware, R., Albers, S., Giuliani, G., Oreamuno, J., Joe, P., Koch, S. E., Cober, S., Westwater, E., Thermodynamic Atmospheric Profiling During the 2010 Winter Olympics Using Ground-Based Microwave Radiometry; IEEE Transactions on Geoscience and Remote Sensing, vol. 49, no. 12, December 2011.
- Han, Y. and Westwater, E. R., Analysis and improvement of tipping calibration for ground-based microwave radiometers. IEEE Trans. Geosci. and Remote Sensing, 38, 1260-1277, 2000.
- Hardy, W. N., “Precision Temperature Reference for Microwave Radiometry” IEEE Trans. on Microwave Theory and Techniques, Vol. 21, No. 3, pp. 149–150, 1973.
- Hewison, T. and Gaffard, C., “MP3000 Microwave Radiometer Performance Assessment”, UK Met Office Tech. Rep., 2003.
- Knupp, K. R., Ware, R., Cimini, D., Vandenberghe, F., Vivekanandan, J., Westwater, E., Coleman, T., Phillips, D., Ground-Based Passive Microwave Profiling during Dynamic Weather Conditions; Journal of Atmospheric and Oceanic Technology, Vol 26, 1057 – 1073, June 2009, DOI: 10.1175/2008JTECHA1150.1
- Löhnert, U., Maier, O., Operational profiling of temperature using ground-based microwave radiometry at Payerne: prospects and challenges; Atmos. Meas. Tech., 5, 1121–1134, 2012; doi:10.5194/amt-5-1121-2012
- Madhulatha, M., Rajeevan, M., Ratnam, V., Bhate, J., Naidu, C. V., Nowcasting severe convective activity over southeast India using ground-based microwave radiometer observations; Journal of Geophysical Research, v. 118, 1–13, 2013, doi:10.1029/2012JD018174
- Marzano, F. S., Cimini, D.; Montopoli, M., Investigating precipitation microphysics using ground-based microwave remote sensors and disdrometer data; Atmospheric Research 97 (2010) 583–600; doi:10.1016/j.atmosres.2010.03.019
- McGrath, A. J and Hewison, T., “Performance assessment of Liquid Nitrogen Calibration Target supplied by Fred Solheim (Radiometrics) at 89, 157 and 183 GHz,” MRF Technical Note 39, Met Office, UK, 2001.
- Pospichal, B., Maschwitz, G., Kuchler, N. and Rose, T., “Standing wave patterns at liquid nitrogen calibration of microwave radiometers”, Proceedings of the 9th International Symposium on Tropospheric Profiling, L'Aquila, Italy, September 2012.
- Radiometrics Corporation; “MP3000A Profiler Operator’s Manual”; Boulder, CO, USA, March 2008.
- Randa, J., et al., “Errors Resulting from the Reflectivity of Calibration Targets”, IEEE Trans. on Geoscience and Remote Sensing, Vol. 43, No. 1, pp. 50–58, 2005.
- Rose, T., Crewell, S., Löhnert, U., Simmer, C., A network suitable microwave radiometer for operational monitoring of the cloudy atmosphere; Atmospheric Research 75 (2005) 183–200; doi:10.1016/j.atmosres.2004.12.005
- Sánchez, J.L., Posada, R., Ortega, E. G., López, L., Marcos, J.L., A method to improve the accuracy of continuous measuring of vertical profiles of temperature and water vapor density by means of a ground-based microwave radiometer; Atmospheric Research 122 (2013) 43–54. doi: 10.1016/j.atmosres.2012.10.024.
- Skou, N., Microwave Radiometer Systems: Design and Analysis, Norwood, Massachusetts, Artech House, Inc., 1989.
- Solheim, F., Godwin, J., Westwater, E., Han, Y., Keihm, S., Marsh, K. and Ware, R., Radiometric profiling of temperature, water vapor, and liquid water using various inversion methods, Radio Sci., 33, 393 – 404, 1998.
- Trembath, C. L. et al., “A Low-Temperature Microwave Noise Standard”, IEEE Trans. on Microwave Theory and Techniques, Vol. 16, No. 9, pp. 709–714, 1968.
- Ulaby, F. T., Moore, R. K., and Fung, A. K., Microwave Remote Sensing, Active and Passive - Microwave Remote Sensing Fundamentals and Radiometry, Volume 1, Artech House, 1986.
- Ware, R., Solheim, F., Carpenter, R., Gueldner, J., Liljegren, J., Nehrkorn, T. and Vandenberghe, F., 2003: A multi-channel radiometric profiler of temperature, humidity and cloud liquid. – Radio Sci. 38, 8079, doi:10.1029/2002RS002856
- Westwater, E. R., Crewell, S., Matzler, C., “A Review of Surface-based Microwave and Millimeter wave Radiometric Remote Sensing of the Troposphere”, Radio Science Bulletin of URSI, RSB-310. September 2004, 59-80, ISSN 1024-4530.